

TECHNICAL DATA

Semco® Model 195 Shot Meter

Disposable component shot meter

- Modular design
- Minimal clean-up
- All parts exposed to compound are disposable
- Remotely actuated
- Positive displacement
- Handles low to high viscosity materials
- Average cycling time from less than one second to about five seconds
- Shot size is from 0 to 13 cc, reproducible +/- 0.02 cc
- Material reservoir is a standard polyethylene cartridge from 2.5 to 32 fluid ounces, (Semkit® package, pre-mixed frozen, hand mix, or one-part), as presently supplied by most adhesive and sealant manufacturers.



Semco® model 195 dispenser

- Pneumatic (requires air at 90 psi maximum)
- Foot control valve attached
- Panel mounted air regulator and gauge included
- Dimensions: 31" x 8" x 15"
- Shipping weight: 20 lbs.

Semco® Model 195 Shot Meter

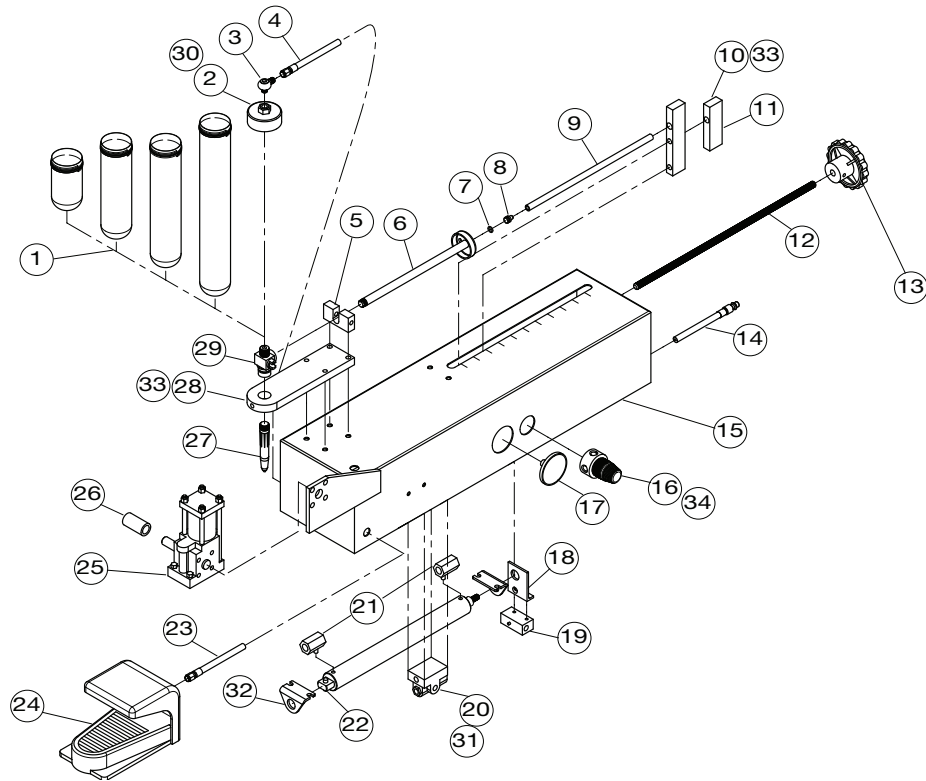

Item	Part no.	Description	Item	Part no.	Description	Item	Part no.	Description
1	(specify retainer—see below)		21	230129	flow control valve	33	271784	thumb screw
2	228963	cap	22	228811	air cylinder	34	231816	ring nut
3	228549	swivel assembly	23	280022	hose assembly	***	231361	body, 20 oz.
4	280066	hose assembly	24	232259	foot valve	***	229795	adapter kit, 20 oz.
5	228959	clamp block		232258	foot valve guard			
	230813	clamp block (20 cc)	25	227669	actuator			
6*	220279	dasher rod	26	228955	couple			Retainers available
	230492	dasher rod (20 cc)	27*		(specify nozzle)			226819, 2.5 oz. retainer
7*	286182	o-ring	28	228954	valve bracket			226820, 6 oz. retainer
	286184	o-ring (20 cc)	29*	228952	valve			226821, 8 oz. retainer
8	228961	piston	**	222078	(polyethylene)			226822, 12 oz. retainer
	223183	piston (20 cc)	* **	229048	valve (stainless steel)			*** 229752 20 oz. retainer assy. (special order 32 oz. available)
9	228958	piston rod			valve body			
10	228960	tie bar		229299	(polyethylene)			* indicates disposable items
11	228956	stop		286184	stainless steel			** indicates optional items
12	228968	screw			valve spool			*** indicates 20 oz. retainer kit
13	229073	knob		286096	o-ring (viton) 2 required			
14	280000	hose assembly			o-ring (teflon) 2 required			
15	228813	box	30	221845	gasket			
16	227562	regulator	31	229071	bracket			
17	227563	gauge	32	229184	mounting bracket			
18	228957	bracket						
19	228810	valve						
20	221415	pilot valve						

Semco is a trademark of PRC-DeSoto International Inc., registered with the U.S. Patent Office.

All recommendations, statements, and technical data contained herein are based on tests we believe to be reliable and correct, but accuracy and completeness of said tests are not guaranteed and are not to be construed as a warranty, either expressed or implied. User shall rely on his own information and tests to determine suitability of the product for the intended use and assumes all risks and liability resulting from his use of the product. Seller's and manufacturer's sole responsibility shall be to replace that portion of the product of this manufacturer which proves to be defective. Neither seller nor manufacturer shall be liable to the buyer or any third person for any injury, loss, or damage directly or indirectly resulting from use of, or inability to use, the product. Recommendations or statements other than those contained in a written agreement signed by an officer of the manufacturer shall not be binding upon the manufacturer or seller.

Printed in the U.S.A.

PRC-DeSoto International, Inc.
12780 San Fernando Road
Sylmar, CA 91342
Telephone (818) 362-6711
Toll Free (800) AEROMIX
www.semcopackaging.com

Issue Date: 06/12
Supersedes: 03/08
Lit: 0636