

Semco® sealant gun assemblies



The Semco® model 250-A sealant gun is the standard of the aerospace and electronics industries. It is designed for quiet pneumatic application of sealants, adhesives, potting compounds, and other materials packaged in Semco® disposable cartridges or Semkit® packages for multi-component materials.

The Semco® model 250-A gun is available with retainers to fit standard 32 cc, 59 cc, 156 cc, 214 cc, and 310 cc (1, 2.5, 6, 8, and 12 ounce) disposable cartridges. Air hoses to operate the gun must be ordered separately.

The gun is constructed of durable metal and engineered plastic parts designed to withstand the rigors of the production work place. The nickel plated retainers are affixed to the valve assembly via a quick connect, secure bayonet lock fixture permitting easy replacement of cartridges. For use in confined locations, the handle can be easily removed to allow more clearance and better manipulation.

Accessories

Hose assemblies to fit the metal multi-axis swivel air fitting are available in 1.5 meter (5-foot) increments with Aro, Hansen, or Schrader air fittings attached. Also available are hose assemblies equipped with a pre-set air regulator to insure the sealant gun is not operated over its maximum pressure rating of 6.9 bar (100 psi).

PRC-DeSoto International provides Semco® brand precision molded cartridges, plungers, nozzles, Sem-Luer™ adapters, and Sem-Needles™. When these disposable plastic products are used in conjunction with the Semco® model 250-A gun, the exact amount of material can be dispensed at the precise location required.

Operation

Attach the air hose assembly to the compressed air source. Some applications may require the user to replace the quick release hose connector with a fitting compatible with local air supply hardware. Unscrew the back knob and disengage the retainer from the valve assembly. Place the cartridge into the retainer and replace the loaded retainer onto the valve assembly. Tighten the back knob until snug. When the trigger is depressed, air pressure pushes against the plunger in the cartridge. This allows for positive, even dispensing of the material.

The material continues to flow until the trigger is released, thereby permitting a drop, shot, or bead to be accurately applied. The amount of material dispensed is determined by the viscosity of material, air line pressure, nozzle or needle orifice size, and length of time the trigger is depressed. When all the material has been dispensed from the cartridge, loosen the retainer by unscrewing the back knob. Remove the disposable cartridge and nozzle. Dispose of leftover material in accordance with local regulations and instructions on the material safety data sheet.

For service, return to point of purchase.

Features

- Reduces applied material cost.
- Provides accurate material control.
- Lightweight.
- Handle can be removed to facilitate application in confined areas.
- 0-6.9 bar (0-100 psi) operating range.
- Available in 32 cc, 59 cc, 156 cc, 214 cc, and 310 cc (1, 2.5, 6, 8, and 12 oz.) sizes.
- Bayonet lock on retainer permits quick cartridge change.
- Durable, shock resistant parts.
- Touch control on trigger regulates flow.
- Positive control for smooth, even dispensing.
- Ergonomic design.
- Quiet operation.

Semco® model 250-A sealant gun assemblies

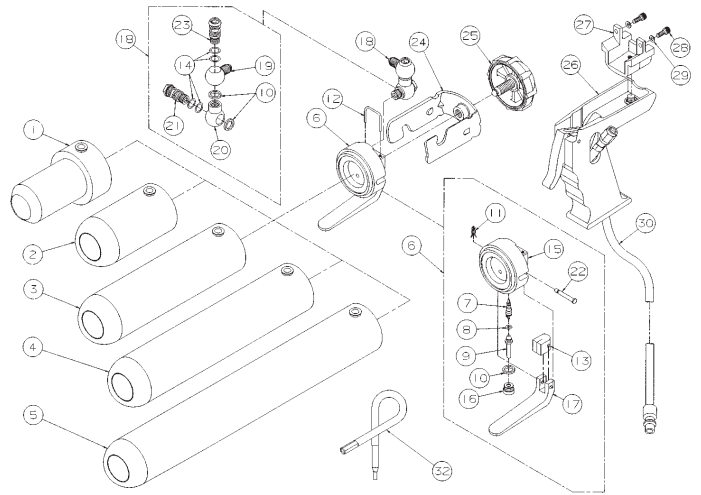

Semco® model 250-A parts list

Item	Part no.	Description
1	231611	Retainer, 32 cc (1 oz)
2	220256	Retainer, 59 cc (2.5 oz)
3	220928	Retainer, 156 cc (6 oz)
4	220926	Retainer, 214 cc (8 oz)
5	220923	Retainer, 310 cc (12 oz)
6	240000 includes	Valve body assembly*
7	items 7, 8, 9, 10, 11,	Valve core, 6.2 bar* (90 psi)*
8	13, 15, 16, 17 and 22	O-Ring
9		Plunger*
10		Washer, hard fiber
11		Hairpin clip*
12		C-Clip*
13		Muffler*
14		O-Ring
15		Valve body
16		Bushing
17		Lever
18	240015 includes	Swivel assembly*
19	items 10, 14, 19, 20,	Swivel
20	21 and 23	Swivel nut
21		Swivel bolt, ext. hex head*
22		Clevis pin
23		Swivel bolt
24	240010	Bracket assembly
25	240012	TPR coated knob assembly
26	240030	Gun handle assembly*
27	240046 includes	Bracket, handle adapter*
28	items 28 and 29	Screw*
29		Washer*
30	see table	Hose assembly
32	240018	Service wrench
	240020 includes	Repair kit
	items 7 - 14	

* These parts are not interchangeable with parts from the Model 250 Gun.

Complete sealant gun (less hose)

Model no.	Assembly no.		Size
	No handle	With handle	
250A-1	250010	250015	32 cc (1 oz)
250A-2.5	250250	250255	59 cc (2.5 oz)
250A-6	250060	250065	156 cc (6 oz)
250A-8	250080	250085	214 cc (8 oz)
250A-12	250120	250125	310 cc (12 oz)

All hose assemblies must be ordered separately. Fitted hoses are available with Hansen, Aro, or Schrader connectors.

For customer assembly and repair of hoses, the following components are available:

Components available

Description	Part no.
Hansen connector assembly	229186
Aro connector assembly	229187
Schrader connector assembly	229188
B-Nut assembly (gun end)	229189
Bulk gun hose (sold by the foot)	220895

Hose Assemblies

Hansen	Schrader	Aro	Length
280000	280006	280012	1.5 m (5 ft)
280001	280007	280013	2.9 m (10 ft)
280002	280008	280014	4.4 m (15 ft)
280003	280009	280015	5.9 m (20 ft)
280004	280010	280016	7.3 m (25 ft)
280005	280011	280017	8.9 m (30 ft)

☞ Complies with Machinery Directive 93/68EEC and Safety Standard EN60292

Semco and Semkit are trademarks of PRC-DeSoto International, Inc., registered with the U.S. Patent Office.

Sem-Luer and Sem-Needles are trademarks of PRC-DeSoto International, Inc.

All recommendations, statements, and technical data contained herein are based on tests we believe to be reliable and correct, but accuracy and completeness of said tests are not guaranteed and are not to be construed as a warranty, either expressed or implied. User shall rely on his own information and tests to determine suitability of the product for the intended use and assumes all risks and liability resulting from his use of the product. Seller's and manufacturer's sole responsibility shall be to replace that portion of the product of this manufacturer which proves to be defective. Neither seller nor manufacturer shall be liable to the buyer or any third person for any injury, loss, or damage directly or indirectly resulting from use of, or inability to use, the product. Recommendations or statements other than those contained in a written agreement signed by an officer of the manufacturer shall not be binding upon the manufacturer or seller.